



CAMPRO NT-2510SM TWIN SPINDLE TURNING CENTER

- The NT-2510SM is Campro's highly flexible and profitable twin spindle CNC lathe.
- Through the use of synchronized control, the 10" Main spindle / 8" Sub spindle can be utilized to complete the greatest amount of primary and secondary turning operations as possible, all in one compact platform.
- High performance heavy duty box guideways, 30 Degree cast iron inclined bed to ensure quick chip evacuation.
- Our NT-2510SM series CNC lathe is based on a high quality cast iron bed for superior strength and vibration characteristics.
- 30 cast iron inclined bed ensure quick chip evacuation. The new CPMS (Campro Production Management System) represents the first step in smart manufacturing.

STANDARD FEATURES:

3-jaw power chuck
Hard jaws = one set; Soft jaws = three sets
Manual tailstock
Chain type chip conveyor with bucket
Coolant system
Oil skimmer
Tool box
Instruction manual, parts list, and electrical diagram
Fanuc operator and maintenance manuals
WARRANTY-Machine: One Year, Parts
WARRANTY-Control: Two Years, Parts & Labor

SPECIFICATIONS:

WORKING AREA:

Swing over bed	24.41" (620 MM)
Swing over cross slides	18.11" (460 MM)
Maximum turning diameter	16.54" (420 MM)
Maximum turning length	20.47" (520 MM)

TRAVEL:

X Axis Travel	8.27" + 1.18" (210 + 30 MM)
Z Axis Travel	20.87" (530 MM)
Rapid Traverse	945 ipm (24 / 24 m/min)

MAIN SPINDLE:

Hydraulic Chuck	10"
Maximum Speed	3,200 RPM
Hole Through Draw Tube	3.00" (75 MM)
Spindle Nose	A2-8
Spindle Motor	20 / 25 HP (15 / 18.5 KW)
Indexing of C Axis	.001 Degree

SUB SPINDLE:

Hydraulic Chuck	8"
Maximum Speed	4,200 RPM
Hole Through Draw Tube	2,047" (52 MM)
Spindle Nose	A2-6
Spindle Motor	10 / 15 HP (7.5 / 11 KW)
Travel	18.90" (480 MM)
Rapid Traverse	590 IPM (15 M/MIN)

TURRET:

O.D. / I.D.	.9842" / 1.5748" (25 / 40 MM)
Turret Type	12-Servo
Maximum Tool Speed	4,000 RPM

GENERAL:

Floor Space Required (W X D)	167.5" X 88.82" (4,254 X 2,256 MM)
Height	72.5" (1,842 MM)
Machine Weight	10,472 LBS. (4,750 KG)
Standard Power Source	205-235 Volts / 3 Phase/60HZ
Power Capacity	71 Amps (25 KVA)

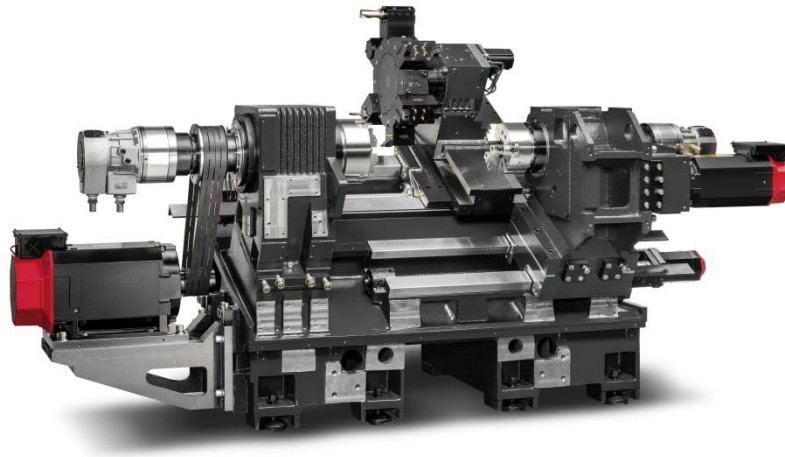

Control Specifications - Fanuc 0i-TF Plus Control

8.4" color LCD screen Color graphics

Simultaneous Controlled Axis

Least input Increment on X, Y, and Z is .001 mm Least command increment on X, Y, and Z is .001mm

Inch/Metric Conversion (G20/G21)

Interlock on All Axes Machine Lock on All Axes Emergency Stop

Stored Stroke Check 1, 2, 3, Mirror Image

Backlash Compensation

Unexpected disturbance torque detection Stored pitch compensation

Automatic Operation (Memory) MDI Operation

Search Function (Sequence, Program) Program restart

Dry Run Single Block Buffer Register

Manual Handle Interrupt

Manual Jog Feed (Rapid, Jog, Handle) Manual Handle Feed Rate (x1, x10, x100)

Feed Command (F Code Feedrate Direct Command) Feedrate Override 0-200% (10% Unit)

Jog feed 0-5,000 mm/min (197 ipm)

Rapid traverse override (F0, F25%, F50%, F100%) Override Cancel

Rapid Traverse Bell-Shaped Acceleration/Deceleration Block Skip

Exact Stop Mode / Exact Stop (G61/G09) Dwell (G04)

Helical Interpolation Threading/Synchronous Feed Manual Reference Point Return 1st Reference Point Return

G28

Reference Point Return Check G27 2nd Reference Point Return G30

3rd and 4th Reference Point Return

Program stop, optional stop, end of pgm. M00, M01, M02, M30 Tape Code EIA RS-244/ISO 840 (Automatic

Recognition) Optional Block Skip (9 ea)

Maximum Programmable Dimensions +/- 9999.9999" (+/- 8 digits) Program Number O4 Digit

Absolute and Incremental Command G90/G91 Decimal Point Input

Plane Selection G17. G18. G19

Work Coordinate System Setting (G52 – G59) Work Coordinate Preset

Additional Work Coordinate System 48 pairs Manual Absolute "On" fixed

Programmable Data Input G10

Sub Program Call 4 Levels of Nesting Custom Macro #100 to #199 Addition to Custom Macro Common

Variables #500 to #999

Circular Interpolation by radius R

Canned Cycle (G73, G74, G76, G80 ~ G89) Optional Chamfering / Corner R

CONTROL SPECIFICATIONS (CONT'D.):

Skip Function (G31)

Automatic Coordinate System Setting Coordinate System Rotation Programmable Mirror Image

Single direction positioning (G60)

External Data Input (Tool Offset, message, machine zero point shift) Cylindrical interpolation

AI Advance Preview Control (G5.1) Polar Coordinate Command Miscellaneous Function (M3 digits)

Miscellaneous Function Lock

Spindle Speed Command (S5 Digits, binary output) Spindle Speed Override (50% ~ 120%) 10% Unit Rigid Tapping

Cutter Compensation C (G40-G42) Tool Length Measurement

Tool Length Compensation (G43, G44, G49) Tool Offset Amount (+/- 6 Digits)

Tool Offset Pairs (400 Pairs) Tool Life Management

Reader/Puncher Interface RS232C Memory Card input/output Embedded Ethernet (100 Mbps) Part Program Storage Length: 320M Registered Programs 400 ea.

Memory Lock

Back Ground Editing

Extended Part Program Editing (Copy, Move, Change of NC Program) Self Diagnosis Function

History Display of Alarm and Operator Message Help Function

Run Hour / Parts Count Display Actual Cutting Feedrate Display Spindle / Servo Setting Screen

Multi-language display (Selection of 5 Optional Language) Erase CRT Screen Display (Screen Saver)

Bi-Direction Pitch Error Compensation Tool Management Function

Protection of Data at 8-Levels

Tool Monitoring Function (HWTM – Built-on Fanuc Type) Fanuc Manual Guide i conversational programming

Alpha i AC digital servo system with 1,000,000 pulse encoders Full MDI keyboard

PCMCIA data card slot on left side of LCD for program input / output – up to 2GB storage

Advanced Preview Control (Look ahead of multi-blocks – 20 blocks look ahead) Automatic Acceleration / deceleration with Bell Shaped rapid acc/dec

3 axes simultaneous control std. (4 axis opt.) Scaling

Custom Macro B

High speed skip signal